

Model WPL Vertical 100 (Channel Frame)
 Typical Precast/Louvre Head Detail 01
 Osborne-Hume Grilles & Louvres Ltd
 Scale 1:5

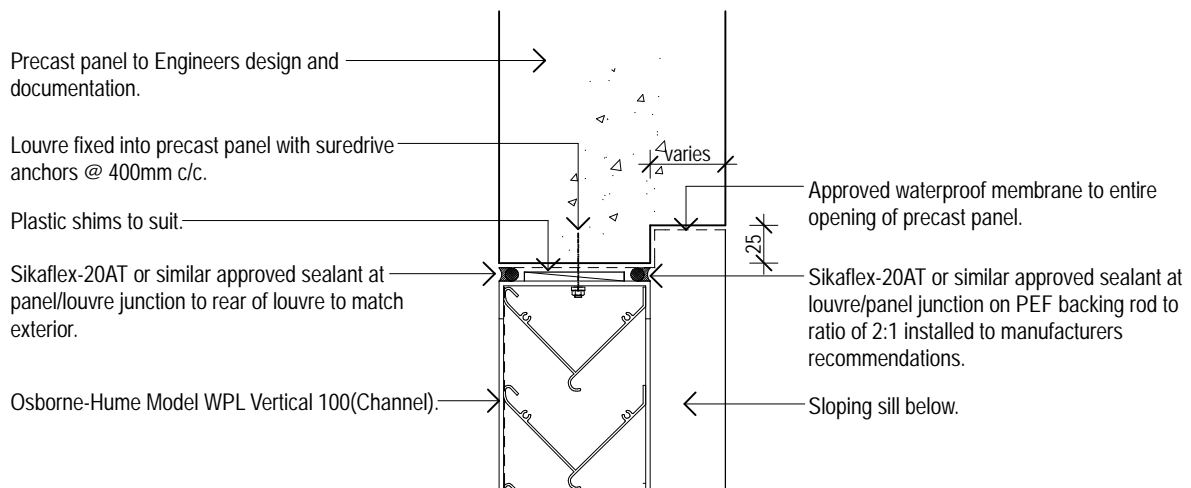

Model WPL Vertical 100 (Channel Frame)
 Typical Precast/Louvre Jamb Detail 02
 Osborne-Hume Grilles & Louvres Ltd
 Scale 1:5

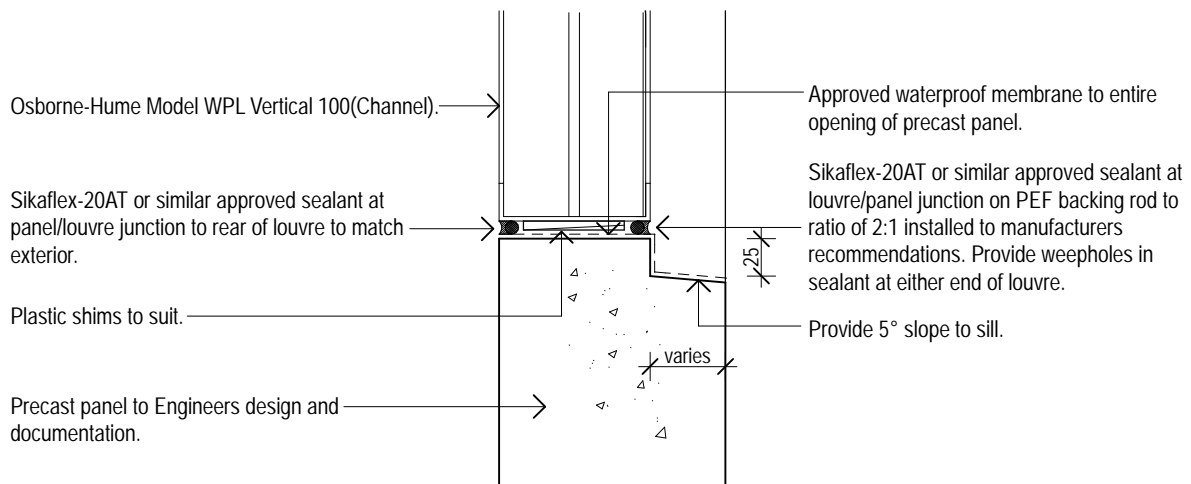

Model WPL Vertical 100 (Channel Frame) Typical Precast/Louvre Sill Detail 03 Osborne-Hume Grilles & Louvres Ltd Scale 1:5

General Notes:

Flashing materials must be selected based on environmental exposure, refer to NZS 3604:1999.

Refer to the manufacturer or supplier for technical information of all materials.

This is an untested alternative solution to NZBC E2/AS1.

This information is intended to be informative and used as a guideline only. Due to the many variables affecting different projects Osborne-Hume Louvres & Grilles Ltd can not replace the judgment or advice of an Architect, Engineer or any other relevant technical expert and such experts must be consulted to determine the suitability or otherwise of the details or the necessity for further design/detailing.