

**Model WPL 80 (Flanged Frame)**  
**Typical Vertical Corrugate/Louvre Head Detail 01**  
 Osborne-Hume Grilles & Louvres Ltd  
 Scale 1:5

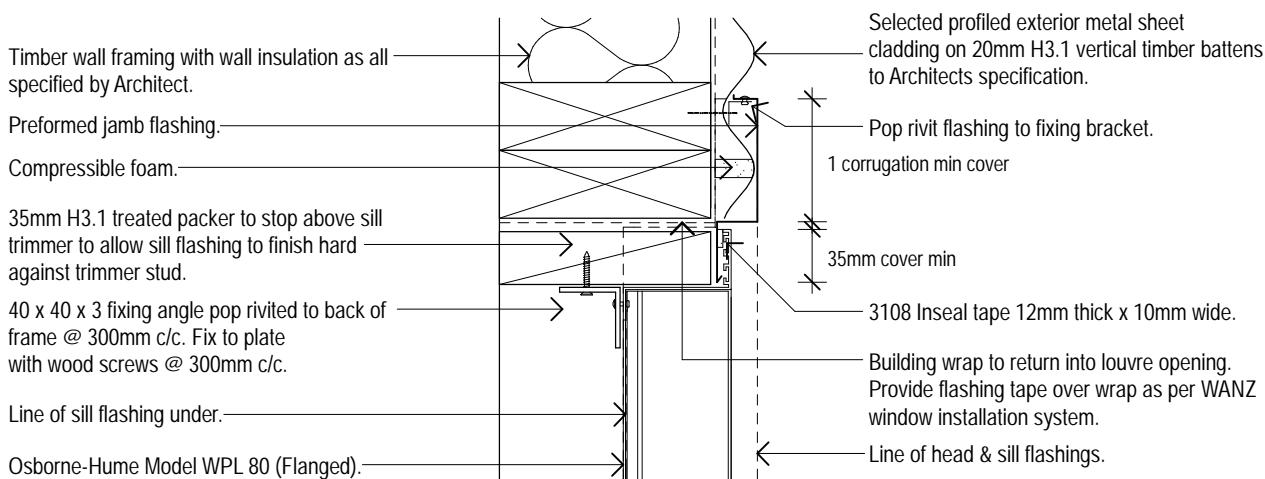

**Model WPL 80 (Flanged Frame)**  
**Typical Vertical Corrugate/Louvre Jamb Detail 02**  
 Osborne-Hume Grilles & Louvres Ltd  
 Scale 1:5

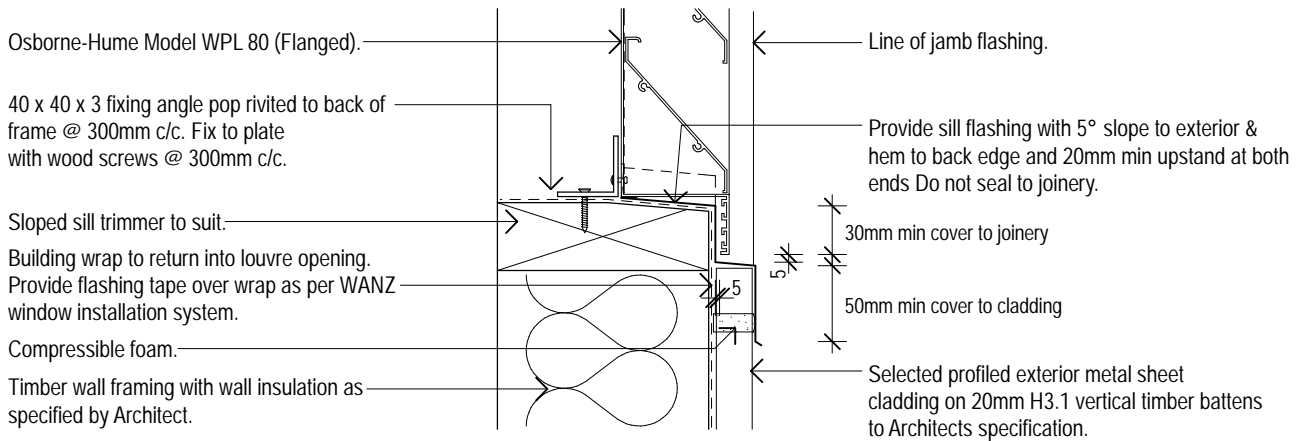

## Model WPL 80 (Flanged Frame) Typical Vertical Corrugate/Louvre Sill Detail 03 Osborne-Hume Grilles & Louvres Ltd Scale 1:5

### General Notes:

Flashing materials must be selected based on environmental exposure, refer to NZS 3604:1999.

Building wrap must comply with acceptable solution E2/AS1 & NZS 3604:1999.

Flashing tape must have proven compatibility with the selected building wrap & other materials with which it comes into contact.

Refer to the manufacturer or supplier for technical information of all materials.

This is an untested alternative solution to NZBC E2/AS1.

This information is intended to be informative and used as a guideline only. Due to the many variables affecting different projects Osborne-Hume Louvres & Grilles Ltd can not replace the judgment or advice of an Architect, Engineer or any other relevant technical expert and such experts must be consulted to determine the suitability or otherwise of the details or the necessity for further design/detailing.